

TIME DOMAIN MEASUREMENT OF SOUND POWER OUTPUT FROM A VACUUM FABRICATION FACILITY.

K.T.Brown ISVR Consulting, University of Southampton, UK
M.G.Smith ISVR Consulting, University of Southampton, UK

1 INTRODUCTION

Measurement of the sound power output of machinery has typically assumed that the result required is independent of time. Indeed, if there are temporal variations most standardized methods^{1,2} would require averaging over a number of cycles of operation in order to give a single value figure. The main application of these measurements has been to establish noise exposures for a workforce, and therefore the long term energy exposure is the critical measure. The classical method depended on indirect measures of sound intensity, in an anechoic or reverberation chamber. With the development of direct methods for the measurement of sound intensity, measurements can often be made in situ, but, again the requirement exists for a continuous output, and, if present, a continuous uninterrupted level of background noise³.

An earlier in-situ method of determining the sound power output of a machine revolved around the use of a calibrated sound power source. This was placed in the same location as the machine, and used in one of two ways. In the first case, if the machine could not be turned off, the sound power from the calibrated source was increased until the sound pressure level at the remote location, such as the operator position, was 3dB higher. Assuming uncorrelated sources, the output level of the source was then equal to the output of the machine. Alternatively, if the machine could be turned off, the sound power source was turned on instead, and adjusted to give the same sound pressure level reading at a remote location. This again gave the sound power output of the machine. This method has also been standardized to give greater precision⁴.

The technique described here is an extension of this method into the time domain. The equipment in question had a long cyclic process which contained a number of discrete noise events. Therefore, on this occasion the requirement was to gain knowledge of the proportion of the total sound power generated by each part of the process, rather than the time averaged sound power output. This information could then be used in a noise control program by ranking the sound power output from each event, and this information could then be used by the manufacturer to concentrating the noise control effort on the most significant contributors. This approach is required by the current Noise at Work Regulations⁵ which place an obligation on manufacturers, and employers to reduce noise at source by all practicable means.

2 APPLICATION.

A semiconductor vacuum fabrication facility, in this case an Edwards Vacuum diFXK system with a single 1000L tank acting as the tool chamber, has been tested to determine the noise characteristics for various operations through the operating cycle. The system consists of vacuum pumps, a vacuum tank and silencer. The vacuum tank is taken down to vacuum by the pumps, vented to allow ingress of doping materials, and finally the vacuum is dumped through the silencer. The process cycle takes about 1 minute. The machine was installed in a workshop at the Edwards



Vacuum site.

Six microphones were arranged around the machine, as shown schematically in figure 1. These were connected to a Bruel and Kjaer Pulse data acquisition system and the microphones were calibrated using a B&K 94 dB calibrator.

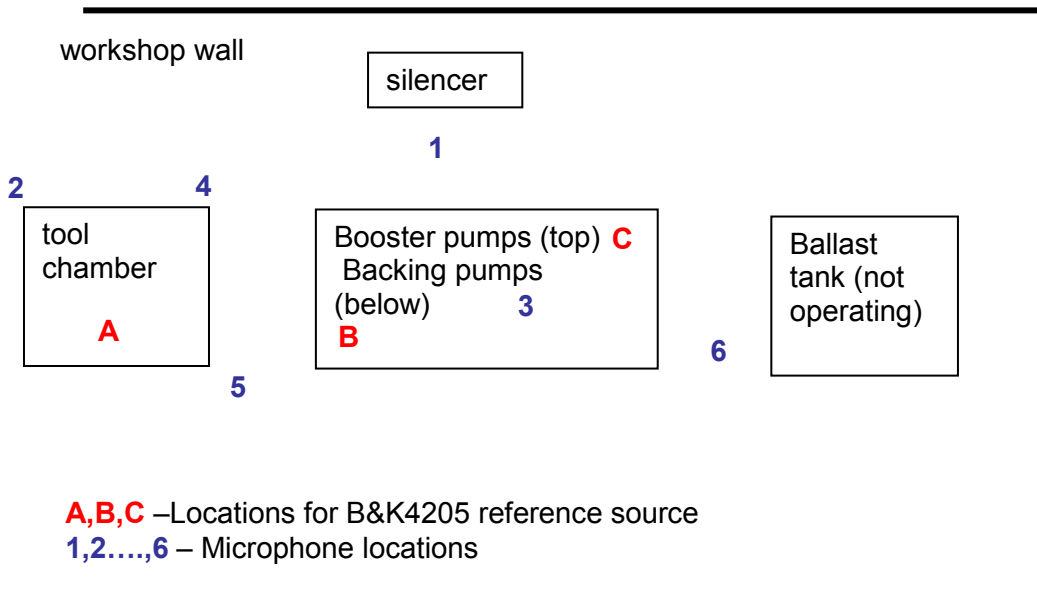

Figure 1: Microphone and source positions around machine in workshop

A Bruel and Kjaer 4205 reference sound source was used to ‘calibrate’ the array of microphones so that the system could be used to calculate the sound power output of the system from the mean level averaged over the six microphones. The method is analogous to the power injection method used in Experimental Statistical Energy Analysis to determine the power inputs to an SEA system⁶.

The reference sound source was mounted at one of the reference source locations shown in figure 1, and switched on in the ‘Broadband’ mode. The source had previously been tested to determine the sound power output for a specified sound pressure level at the reference microphone location on the sound source. The SPL and corresponding PWL data for the sound source are shown in figure 2.

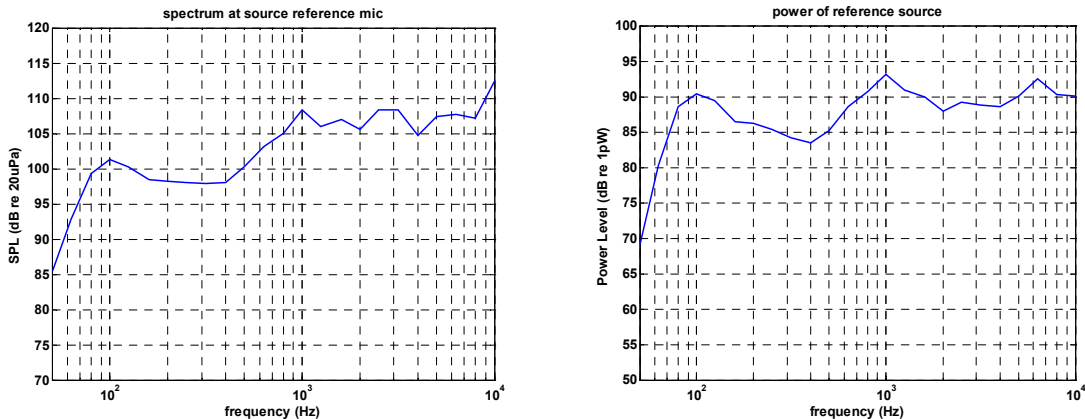

Figure 2: a) Sound pressure level at the reference microphone location of the sound source b) sound power level of the sound source

Next, the sound pressure level due to the sound source at each of the six microphone locations was measured and the spatial average SPL was determined. This was repeated for the sound source at each of three locations A,B and C with the resulting levels as shown in figure 3. The fact that there is relatively little variation in these results is an indication that the microphone array can satisfactorily determine a reverberant field level for the distributed sources of noise on the Edwards Vacuum machine.

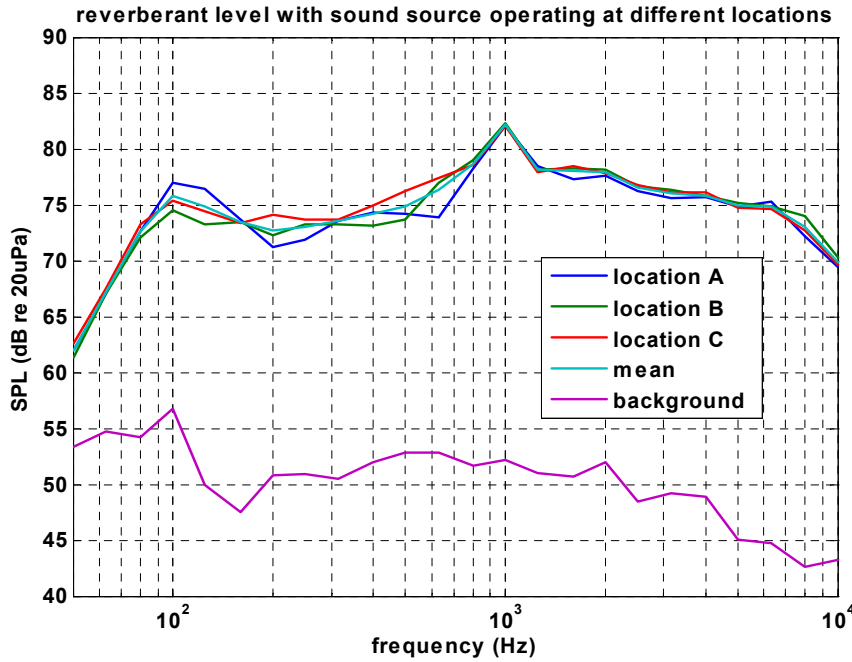

Figure 3: Spatial average of sound pressure levels for each source position in 1/3 Octave bands

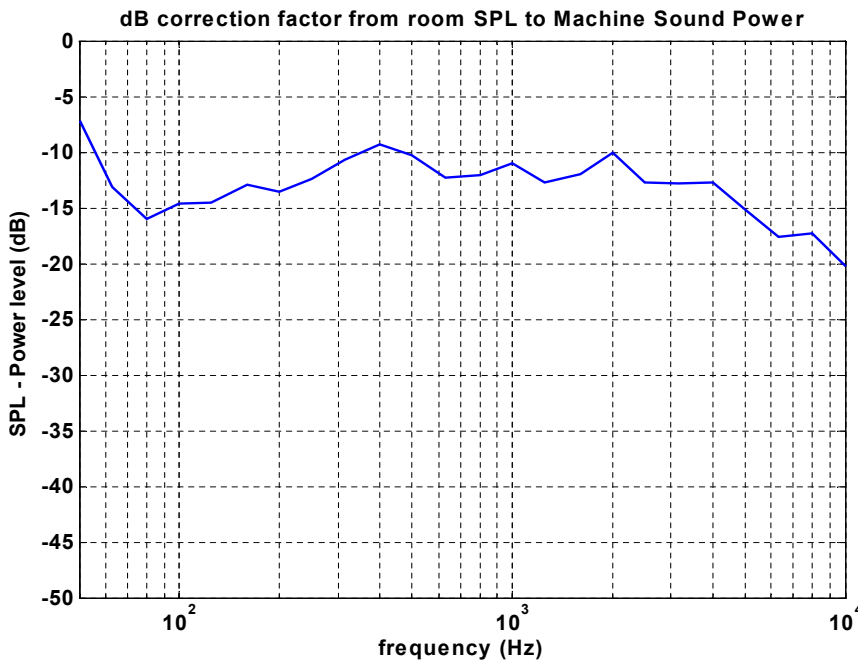

Figure 4: 1/3 Octave band correction factor from SPL to PWL for this work space

Combining the power data from figure 2 with the data presented in figure 3 enables us to calculate a frequency dependant conversion factor from a measured reverberant level in the room to the power output of the source of noise, shown in figure 4. The conversion factor will be dependant on the reverberation time of the room, hence absorption etc, although it is not necessary to specifically calculate the rev time. The factor will also depend to some extent on the modal characteristics of the room, the selected locations of the sound source and microphones, and the directivity of the reference source, thus the aim of using a large number of source and receiver locations average out these effects.

3 RESULTS WITH THE MACHINE OPERATING

The machine was operated for three full cycles, and the spectrum of noise was captured at approximately 2000 time points, spaced 0.099 seconds apart. The total duration of each recording was thus about 198 seconds. Figure 6 shows the time history of the overall A-weighted sound pressure level during the three cycles, and using the measured conversion factor this may be replotted as machine sound power as shown in figure 7.

From the short duration of the peak event it is clear why the time domain approach was used. Other methods such as sound intensity mapping around the various component parts of the machine would have struggled to provide accurate data in these circumstances.

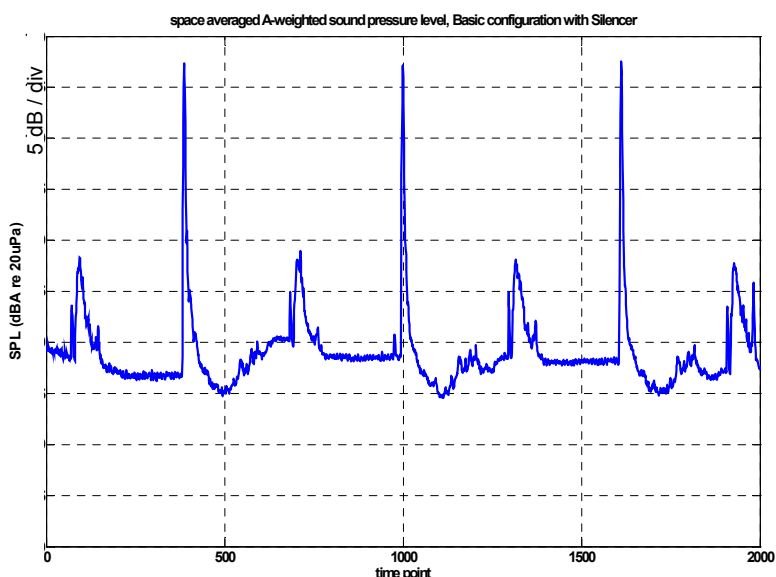

Figure 6 Time history of the space-average A-weighted sound pressure level over three machine cycles

Clearly the peak in sound power output as the tool chamber dump occurs dominates the sound power output of the machine. The steady state noise level of the combined booster and backing pumps, can be seen in this transient data and, although the level does vary a little over the three cycles, it is clear that the average level over this period is well below the peak of the cycle.

To further demonstrate the dominance of the peak noise level, the cumulative power (presented on a linear scale) throughout the three cycles of operation is shown in figure 8. From this it can be seen that the short intense bursts of noise from the tool chamber dump is responsible for approximately 75% of the total A-weighted sound power output of the machine.

The ratio of 75:25 between the power of the primary and secondary sources is indicative of a difference in level of about 5dB, which gives an indication of the degree of noise control required on the dump process before it is necessary to tackle the other sources of noise.

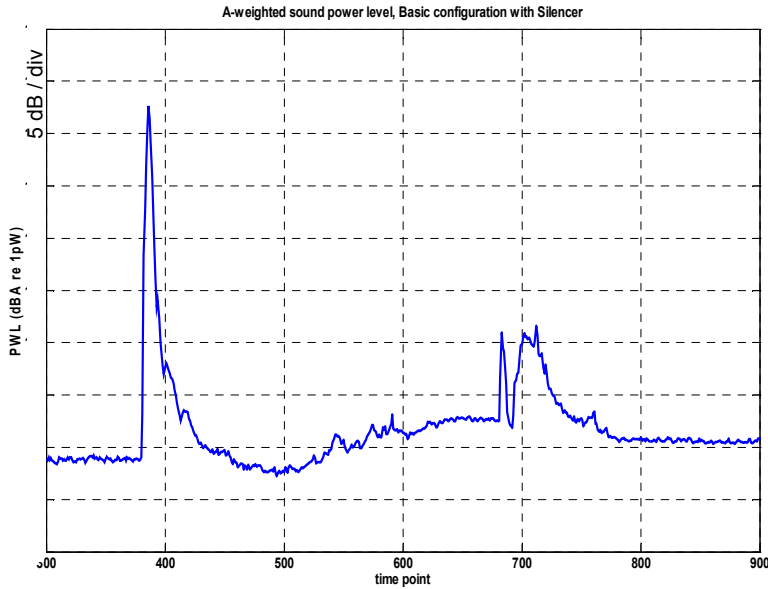

Figure 7 A-weighted sound power output as a function of time during a single cycle.

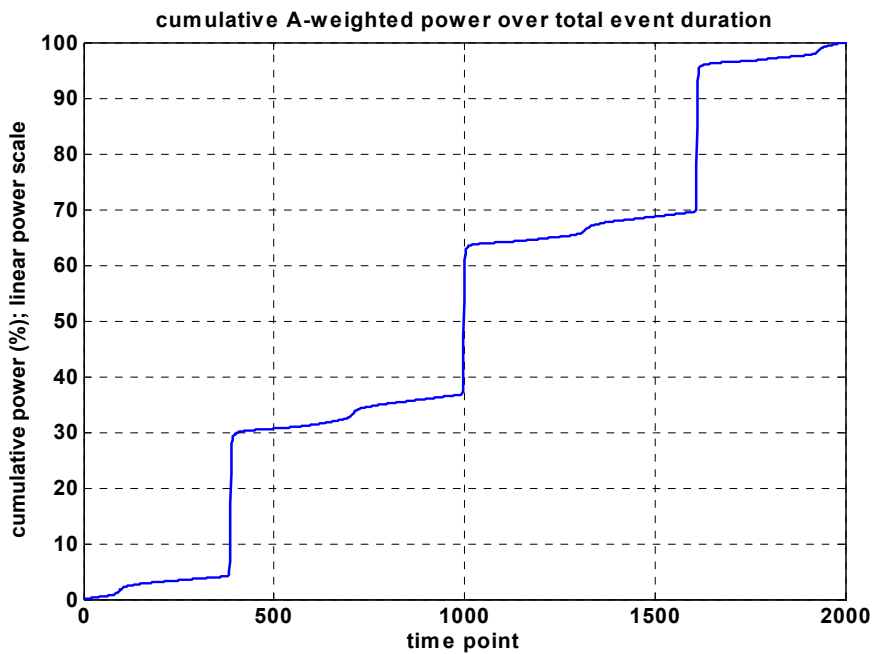

Figure 8 Cumulative A-weighted sound power level throughout three machine cycles

From the data on the expanded time scale of figure 7 further information on the relative levels of secondary sources of noise can be identified. In particular the vent noise peaks at a lower level than the dump noise, presumably because the pressure drop and jet velocity associated with the vent expansion is lower than for the dump. Other short duration peaks in the noise are apparent

before during and after the vent, although the power of these is low compared with the total over the cycle.

4 SPECTRAL TIME HISTORY INFORMATION

The processing presented so far used 1/3 octave band analysis of the time data, essentially the data presented in figure 8 showing the 1/3rd octave band frequency levels for the three machine cycles.

However, more detailed diagnostic information can be obtained by presenting the data as a narrow band waterfall plot of the machine operation; figure 10 shows the data for microphone 2. From this type of plot the presence of tones from the backing and booster pumps are evident. These change frequency slightly during the course of the cycle, although this is not very clear on this scale, which is a function of the varying pressures in the system during the machine cycle.

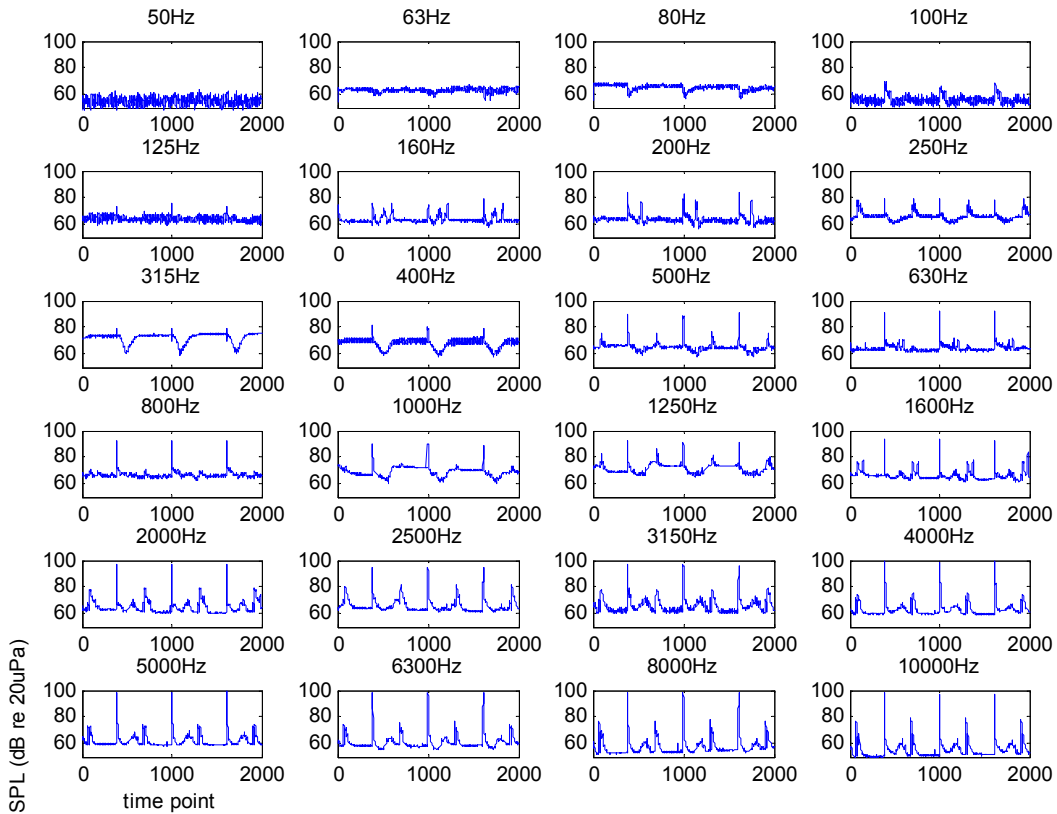

Figure 9. Time domain display of sound pressure level in each 1/3 octave

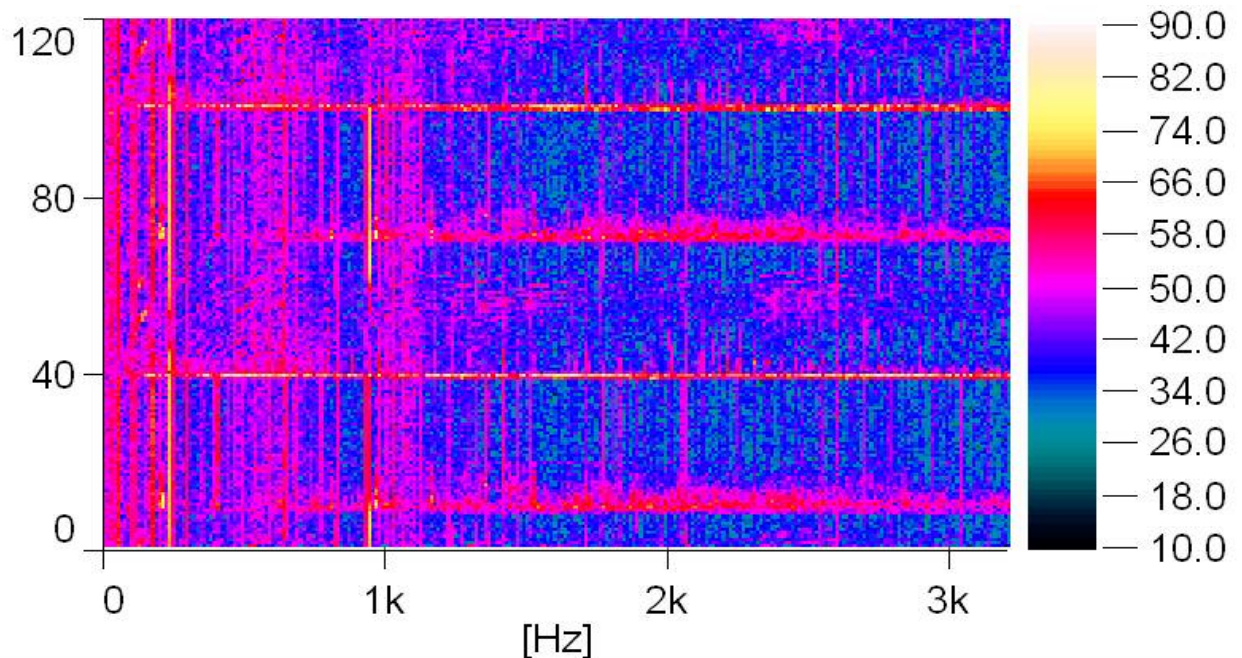

Figure 10 Narrow band sound pressure level at microphone 2 shown over three machine cycles

5 ACKNOWLEDGEMENTS

ISVR Consulting would like to thank David Manson of Edwards Vacuum for permission to publish the data shown in this paper.

6 REFERENCES

1. BS EN ISO 3741:2000 Acoustics. Determination of sound power levels of noise sources using sound pressure. Precision methods for reverberation rooms
2. BS EN ISO 3745:2003 Acoustics. Determination of sound power levels of noise sources using sound pressure. Precision methods for anechoic and hemi-anechoic rooms
3. BS EN ISO 9614-3:2002 Acoustics. Determination of sound power levels of noise sources using sound intensity. Precision method for measurement by scanning
4. BS EN ISO 3747:2000. Acoustics. Determination of sound power levels of noise sources using sound pressure. Comparison method in situ
5. Statutory Instruments 2005 No. 1643; *Health and Safety. The Control of Noise at Work Regulations 2005*. The Stationery Office, London. ISBN 0 11 072984 6
Available on line at <http://www.opsi.gov.uk/si/si2005/20051643.htm>
6. K. De Langhe and P. Sas Statistical Analysis of the power injection method. *Journal of Acoustical Society of America*, 100(1), 294-303. 1996